

JUNE 2010

# Field Testing Installed Optical Fiber Cabling

---

BY: JAY PAUL MYERS, RCDD  
TECHNICAL TRAINING SPECIALIST  
LEGRAND | ORTRONICS

BY: JASON TARN  
PRODUCT MARKETING MANAGER  
FLUKE NETWORKS

**FLUKE**  
*networks*  
• • • • •

 **legrand**<sup>®</sup>

---

**Ortronics**

# WHITE PAPER

## Field Testing Installed Optical Fiber Cabling

This joint white paper prepared by Legrand | Ortronics and Fluke Networks reviews best practices for the technician performing field tests on installed optical fiber cabling. As traffic over networks expands and expectations of reliability increase, testing optical fiber cabling after installation is more important than ever before to assure the end-user that the installation was done properly and that the cabling will support Local Area Networks (LAN) into the future.

The table below illustrates that newer, high performance LANs such as Gigabit Ethernet and 10 Gigabit Ethernet allow for much less loss in cabling than older networks allowed. Even higher performance networks in development, such as 40/100 Gigabit Ethernet, will likely continue this trend.

These newer applications also use vertical cavity surface emitting lasers as drivers which light up a much smaller area of the fiber core compared to older Light Emitting Diode (LED) drivers, so that the quality of the connector finish in this small area is more important. Both of these factors make proper cable handling, termination and cleanliness practices critical. Only proper testing can certify that the installed cabling will perform up to the requirements of industry standards and that the system owner is getting the performance specified.

### PART 1: TIA STANDARDS PERFORMANCE REQUIREMENTS

TIA-568-C.0 specifies field testing optical fiber for the end-to-end attenuation of an installed link and gives recommended acceptance values based on the link length and number of connections. Many other performance parameters are important, such as bandwidth, but these are tested only at the factory since they are not affected by installation practices and are difficult to measure in the field.

TIA-568-C.1 specifies three types of fiber cabling links for commercial building installations:

1. Horizontal: up to 90m in length, from a Telecommunications Room (TR), Equipment Room (ER) or Telecommunications Enclosure (TE) to a work area, which may include an optional Consolidation Point (CP).
2. Backbone: cabling between two telecommunications spaces such as TRs, TEs, ERs and entrance facilities (EF), with distance limits determined by the network application in use, according to the supportable distances listed in TIA-568-C.0 Annex D.
3. Centralized: a special exemption from the 90m horizontal link limit; a backbone link and a horizontal link may be interconnected or spliced to extend the distance between electronics in the ER and the work area beyond 90m according to the supportable distances listed by application in TIA-568-C.0 Annex D; continuous pull-through fiber links are still limited to 90m.

2

YEAR	APPLICATION	DATA RATE	DESIGNATION	STANDARD	CABLE PLANT LOSS BUDGET (dB)
Early 80's	Ethernet	10 Mbps	10BASE-FL	IEEE 802.3	12.5
Early 90's	Fast Ethernet	100 Mbps	100BASE-FX	IEEE 802.3	11.0
Late 90's	Short Wavelength Fast Ethernet	100 Mbps	100BASE-SX	TIA/EIA-785	4.0
2000	1 Gigabit Ethernet	1,000 Mbps	1000BASE-SX	IEEE 802.3z	3.2
2004	10 Gigabit Ethernet	10,000 Mbps	10GBASE-SR	IEEE 802.3ae	2.6

Shrinking loss budgets



# WHITE PAPER

## Field Testing Installed Optical Fiber Cabling

The wavelengths for testing are specified by TIA-568-C.0:

Link type	Wavelengths MM	Wavelengths SM
Horizontal	850nm <b>or</b> 1300nm	1310nm <b>or</b> 1550nm
Backbone	850nm <b>and</b> 1300nm	1310nm <b>and</b> 1550nm
Centralized—pull through	850nm <b>or</b> 1300nm	1310nm <b>or</b> 1550nm
Centralized—interconnect/splice	850nm <b>and</b> 1300nm	850nm <b>and</b> 1300nm

For all links, allowed loss is calculated with the following formula:

**Link attenuation = Cable attenuation + Connector insertion loss + Splice insertion loss**

**Component loss values are specified by TIA-568-C.3:**

- 0.75 dB maximum loss for each mated pair of connectors
- 0.3 dB maximum loss for each splice
- 3.5 dB/km loss for multimode fiber at 850nm
- 1.5 dB/km loss for multimode fiber at 1300nm
- 1.0 dB/km loss for singlemode fiber in indoor cable (both wavelengths)
- 0.5 dB/km loss for singlemode fiber in outdoor cable (both wavelengths)

TIA-568-C.0 requires testing each link in only a single direction.

Many in the industry feel that the above requirements are relatively lax. For example, the allowance for a 90m horizontal link at 850nm based on 0.75dB for the mated pair at each end, plus 0.32dB for cable loss, would be 1.82dB. A typical mated pair of SC connectors might show 0.3dB to 0.4dB loss and a mated pair of LCs might show 0.1dB. A skilled technician may achieve even better performance. Two mated pairs of 0.3dB each, plus the cable loss of 90m of fiber at 850nm should actually be 0.92dB or

better, even though the standard allows almost twice that much loss as acceptable.

TIA-568-C.0 provides additional recommendations for field testing. Two tiers of certification testing are specified:

**Tier 1 testing is required to be compliant with the standard and includes:**

- Attenuation, typically tested with a Light Source and Power Meter (LSPM) or Optical Loss Test Set (OLTS)
- Link length, determined by test equipment or from cable jacket markings
- Polarity, to make sure that a transmitter on one end of the fiber will connect to a receiver at the other end

**Tier 2 is optional and includes:**

- Tier 1 testing
- Optical Time Domain Reflectometer (OTDR) testing

An OTDR works by injecting many pulses of light into a fiber and measuring back-scattering and reflection of the pulses caused by imperfections in the fiber or interruptions in the fiber pathway from components such as connectors and splices. By noting the timing of these reflections the OTDR can calculate the distance to these “events.”

Testing with an OTDR is often most valuable as a diagnostic step to find a problem—it is ideal for locating the cause of high loss. For example, if an outside plant cable run between buildings contains three splices and shows high loss and cleaning the connectors or re-termination does not correct the problem, an OTDR can show which of the splices or which length of cable is the likely cause of the high loss measurement.

# WHITE PAPER

## Field Testing Installed Optical Fiber Cabling

### PART 2: TESTING PRACTICES

Testing practices are specified in TIA-526-14A for multimode and TIA-526-7 for singlemode fiber.

Loss is most accurately measured by injecting a known amount of light into one end of a fiber and measuring how much comes out the other end. This can be done with a light source and an optical meter, often referred to as an Optical Loss Test Set (OLTS) or Light Source and Power Meter (LSPM). This may also be done with a certification tester that performs loss and length measurements in an automated manner, calculates the allowable link loss according to length and number of connections and records and stores information to produce professional test reports.

While the basic concept of testing for loss is simple, many misconceptions about the details of testing are prevalent throughout the industry. Misinformation persists even in much of the training that is done, both in formal classroom training and informal on-the-job training.

### CALIBRATION

Before testing, the test equipment must be calibrated and a reference point set to determine the baseline amount of light that the source is injecting into the launch cord.

Time for a pop quiz! A standard test set-up is shown below. Note that this is a certification tester set which is testing two separate links at the same time, the equivalent of having two separate sets of sources and meters.

Which of the following is the correct method to calibrate and set a reference for a premises cabling fiber project?

Don't cheat! Pick one before reading any further!

METHOD A

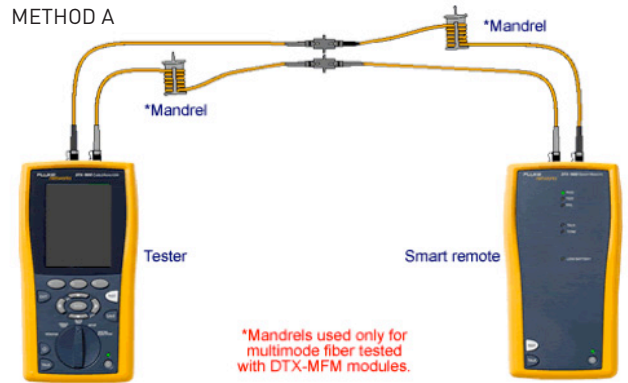

METHOD B

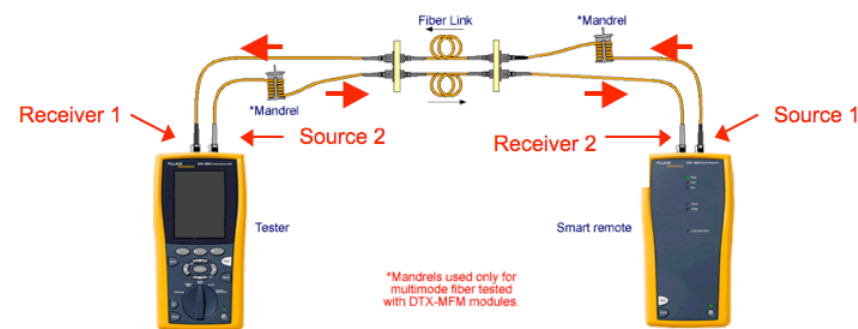
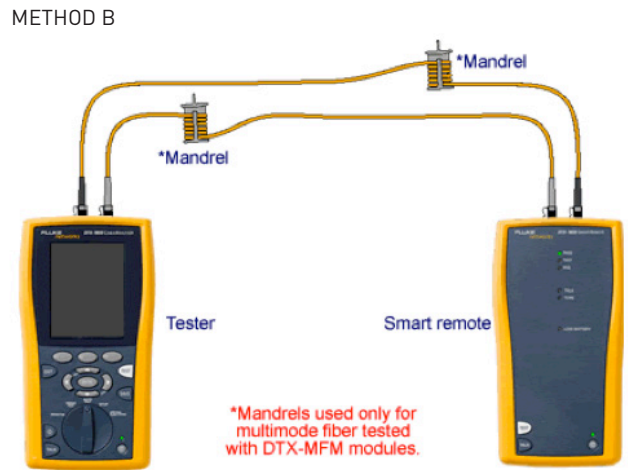

## WHITE PAPER

### Field Testing Installed Optical Fiber Cabling

---

If you picked Method A, you are in good company. More than 95% of technicians pick Method A. The correct answer, however, is Method B. TIA-568-C.0 specifies TIA-526-14A Method B for multimode and TIA-526-7 Method A.1 for singlemode, both using a **single jumper** for calibration in each testing pathway.

Two plausible reasons for this misconception are that, first, most people are trained (incorrectly) to calibrate and set a reference with both jumpers. Second, it passes the LAR test—it Looks About Right. It seems logical that everything in the test setup should be present at calibration except the link being tested. By referencing out everything except that link during calibration, it would seem to give us an accurate measurement of the link itself.

The reason this interpretation is not correct is because the purpose of calibration is **not** to measure the loss caused by the two jumpers. Assuming we know the jumpers are in good condition (we will look at how we know that in a moment), the loss they contribute is insignificant. A few meters of fiber contribute negligible loss and we know that the connectors are good (stay tuned to see how we know this).

What we are really measuring during calibration is how much light is being injected into the launch cord by the light source. This amount varies from jumper to jumper, even if all have good connectors. It will even vary if the **same** connector is plugged into the source multiple times. This is why the setup should be recalibrated and the reference set again if the launch cord is ever disconnected from the source. Once we know the amount of light being coupled into the launch cord, and thus into the installed connectors and cable, we can compare this to the amount of light emerging from the link being tested and the difference is an accurate measure of link loss.

A connector, by itself, cannot be tested—it

must be mated with a known good connector to discover how well light will pass from one to the other. When we test a link, we are verifying that the connectors on each end can receive light from a known good connector and can transmit light into a known good connector. This is the primary test for an installed connector to verify its performance. We are also verifying that the cable itself has not been compromised by over-stressing, crushing, breaking or overly-tight bending.

Using two cords during calibration does not give an accurate measure. When we are testing the link, we are measuring the loss from the two mated pairs of connectors (one at each end) plus the loss from the cable in between. This means that **after calibration** we must add **two mated pairs** of connectors to the test setup. Certification testers ask the technician this question or something similar: “How many mated pairs of connectors have been added?” and the technician must be able to answer “two.” If the test setup is calibrated with two jumpers, one mated pair has been referenced out of the measurement and only **one** mated pair is included in the measurement—the loss measurement is artificially and improperly reduced.

For these reasons, even though 95% of the industry would pick Method A in the pop quiz above, and even though it looks logical at first, and even though many people are trained this way, the correct way to calibrate for testing a premise cabling project is with a **single jumper** in each testing pathway. TIA-568-C.0 states this clearly. Incidentally, there are two-jumper and three-jumper calibration methods in the TIA-526 standards but these are intended for other applications such as cable installed with no panels, jumpers or adapters, or longer outside plant runs where most of the loss is contributed by the cable and the connectors are of less concern.

# WHITE PAPER

## Field Testing Installed Optical Fiber Cabling

### TESTING FIBER JUMPERS

The procedure to make sure the launch and receive cords are in acceptable condition is described in TIA-568-C.0 Annex E. Connect a source and a meter with a single jumper and take an actual power reading (a dBm measurement, rather than dB). Unplug the jumper from the meter, add an adapter and a second jumper, then plug the second jumper into the meter. The power reading should be within 0.75dB of the first reading. Then unplug the second jumper and swap ends. The reading should still be within 0.75dB of the original reading. Greater assurance of consistency can be had by repeating the process after exchanging the positions of the two cords. Better consistency can also be gained by reducing the allowable variance to 0.5dB for SCs and perhaps 0.2dB for LCs.

### MANDRELS

One additional practice is needed to make the most accurate measurements of loss and is specified by TIA standards: the use of mandrels.

The standards specify using a mandrel, a smooth rod, during calibration and testing. A multimode launch cord is wrapped five non-overlapping times around the mandrel before calibration. Consistency can be improved by taping the cord around the mandrel and securing this assembly to the source to reduce undesirable movement of the launch cord in relation to the source.

The diameter of the mandrel is determined by the launch cord core size and construction.

Cordage type	Mandrel diameter (inches)	Mandrel diameter (mm)
62.5/125 3mm jacketed	0.7	17
62.5/125 tight buffered	0.8	20
50/125 3mm jacketed	0.9	22
50/125 tight buffered	1.0	25

Singlemode launch cords should have a single 30mm (1.2") loop.

The purpose of the mandrel in multimode testing is to remove the modes, or pathways, of light near the outer edge of the core.

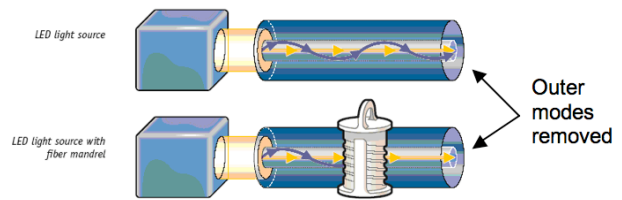

Without a mandrel these outer modes of light will make it through the short launch cord to the meter during the calibration step and be included in the reference measurement. When the link test is performed, the normal bends and connections of an installed link will cause these outer modes to be lost, somewhat exaggerating the amount of loss contributed by the installed link. Since this light will nearly always be lost in any typical installed link, using a mandrel gives a more realistic measurement by removing these outer modes before the reference is set.

Most technicians do not use mandrels—in fact, many have never seen one. They still receive acceptable test results since, as noted above, the acceptance values specified in the standards are relatively lax. The effect of using a mandrel in a particular test can vary, since drivers vary in how much light they inject into the outer modes. Failing to use a mandrel can incorrectly increase the loss measurement, and possibly cause a false failure. If unexpectedly high loss is encountered in an installed link, using a mandrel may be part of the process of resolving that high loss.

# WHITE PAPER

## Field Testing Installed Optical Fiber Cabling

### METHOD B ADAPTED

The Method B described above for multimode fiber assumes that the connectors installed in the cable plant match the adapter type in the test equipment. With the introduction several years ago, and recognition by TIA-568-C.3, of five new small form factor connectors, this is not always the case.

For example, to test installed LC connectors with testers equipped with SCs, hybrid jumpers, SC to LC, must be used. This makes single-jumper calibration and reference setting impossible—the SC to LC launch cord cannot plug into the SC adapter in the meter. Some newer testers are designed with changeable adapters that make this adaptation unnecessary, but many existing testers do not have this feature.

While TIA has not yet addressed this issue, a solution has developed informally in the industry, often called “Method B adapted.” With this method, calibration is done with two hybrid jumpers connected with an adapter. Note that this illustration shows a certification tester which tests two pathways in opposite directions at the same time. The method described is for each pathway.

To get an accurate measurement of the loss in an installed link, however it is still necessary to **add two mated pairs** of connectors to the test setup **after calibration**, just as with single-jumper calibration.

To do this, an additional short jumper must be added in each pathway after calibration and before testing the links.

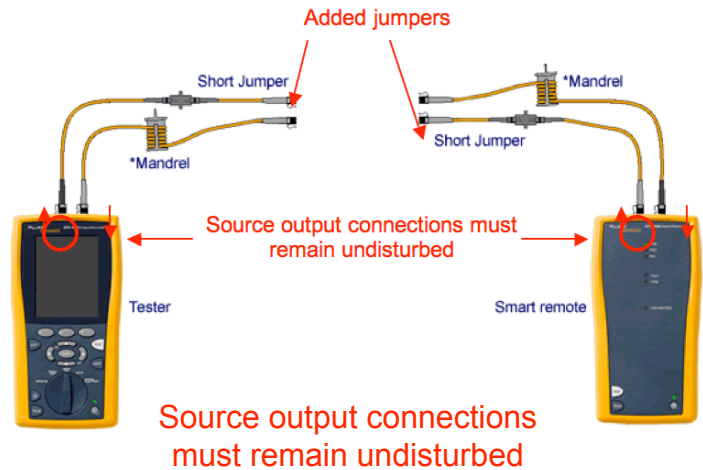

Since one mated pair was referenced out at calibration, adding a third jumper gives a total of three mated pairs in each pathway—as required, two mated pairs are added after calibration for the actual test.

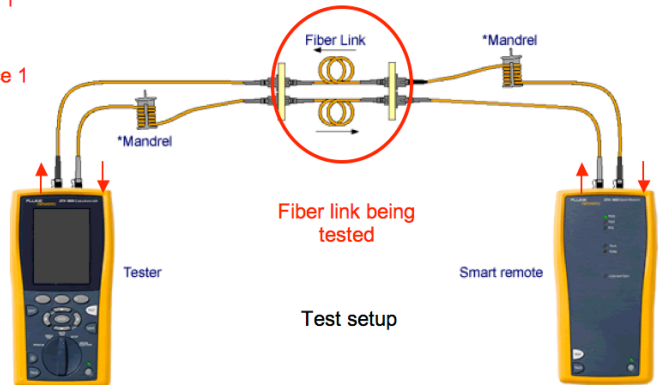
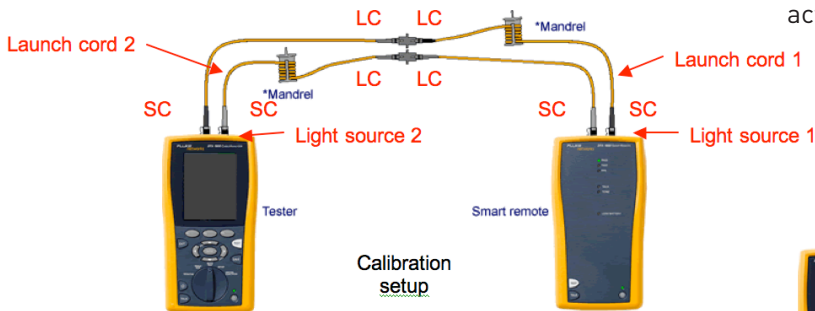

# WHITE PAPER

## Field Testing Installed Optical Fiber Cabling

Many installers use certification testers as shown above instead of an OLTS or LSPM. While generally more expensive, they offer certain benefits:

1. Technicians can be more productive—they can perform more tests in the same amount of time.
2. A certification tester produces test reports showing conditions of each test, such as the wavelength used, and this is perceived as more professional by many in the industry. Some LSPM sets also input measurement information into professional test reports.
3. They make bi-directional testing easier, a practice recommended by many in the industry. Though not required by TIA-568-C.0, this is required by some cabling manufacturers for a project warranty.
4. In addition to measuring loss, they accurately measure fiber length in order to calculate allowed loss; having the certification tester determine length provides greater certainty since actual fiber length can vary somewhat from the length determined from cable jacket markings.
5. Certification testers automatically compare loss measurements against various standards and return a PASS or FAIL result. With an OLTS or LSPM, the technician must make this determination manually.

Many of these certification testers are 4-pair copper cable testers with optional fiber modules installed.

### CAVEATS

Even when proper testing in accordance with the standards shows compliant results, end-users should beware of certain situations that can cause problems in actual operation.

First, TIA installed performance requirements are lax compared to typical performance achieved in actual installations. As a result, receiving a PASS result (meaning standards compliant loss) does not ensure that all connections are properly terminated and clean. For example, in a horizontal link 90m long, tested at 850nm, terminated with LCs, with 0.1dB loss at one end and 1.3dB loss at the other end, due to a bad or dirty connector, a tester will show PASS—the total loss will be 1.72dB, less than the standard limit of 1.82dB. Thus, a PASS result can conceal a bad connector.

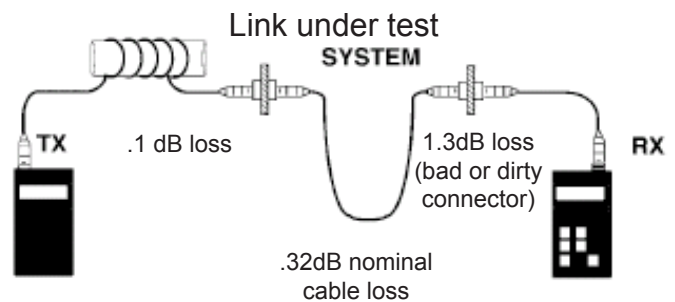

This problem is exacerbated when testing multiple links end-to-end through cross-connections or inter-connections, a practice allowed by the standards. For example, in a campus setting, as shown below, it is easy for a bad connector to be concealed. The losses shown are typical of what a skilled technician might achieve with SCs. LC connectors would typically show even lower loss.

# WHITE PAPER

## Field Testing Installed Optical Fiber Cabling

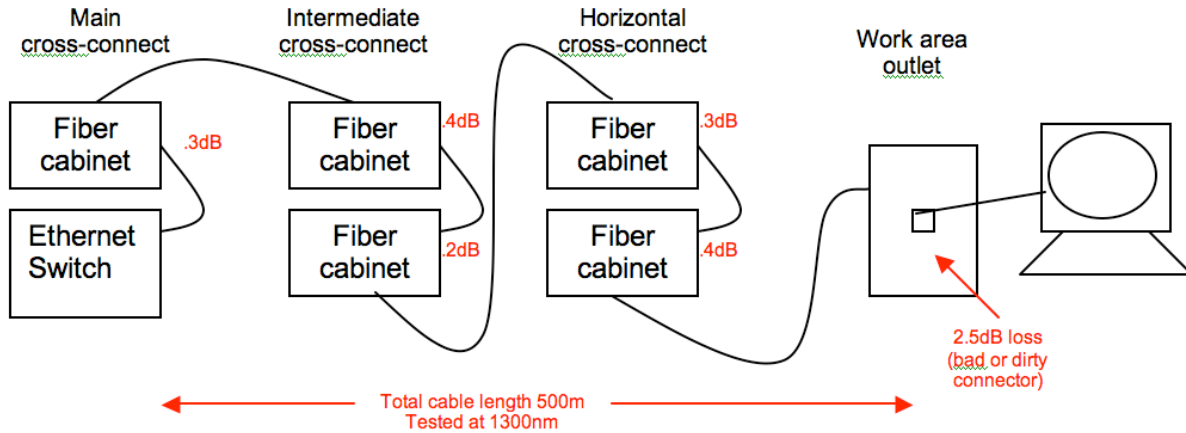

Allowed loss per TIA-568-C.0 and C.3:

Connector loss + cable loss = allowed link attenuation

$$6 \times .75\text{dB} + 500\text{m} \times 1.5\text{dB/km} = \underline{5.25\text{dB}}$$

**“PASS” result, despite bad connector**

Actual loss

$$.3\text{dB} + .4\text{dB} + .2\text{dB} + .3\text{dB} + .4\text{dB} + \underline{2.5\text{dB}} + .75\text{dB (cable)} = \underline{4.85\text{dB}}$$

To avoid these problems, the technician should have a clear idea of the actual loss typically achieved with the connectors and cable being installed—for example, 0.3dB to 0.4dB for SCs and 0.1dB to 0.2dB for LCs. The installer should expect actual loss readings based on these numbers and not just rely on a “PASS” result. If possible, the technician should test each link individually. The margins can also be monitored between standards requirements and actual results reported by a certification tester. In most cases, the margin should be close to 50% of the standards-based performance required—the actual performance should beat the standard by nearly half. Testing with an OTDR is another alternative to quickly pinpoint a bad or dirty connector.

A second problem is that TIA-568-C.0 specifies testing in only one direction. (The default requirement of TIA-526-14A is bi-directional testing, but this requirement may be omitted by

the specifier.) A flawed termination will often show different results when tested in different directions. A poor termination may cause loss by failing to focus light into the next polished fiber end-face; the light is scattered at higher angles into higher order modes which are more likely to be lost at bends in the fiber. If a poor termination is at the far end from the light source and the light is scattered only a few feet from the meter, much of the light may make it through that last few feet to the meter and show little loss. If the termination scatters light at the beginning of the run, near the source, much more of the light is likely to be lost over the length, connections and bends of the installed link, resulting in greater measured loss.

Bi-directional testing can reveal such flaws that may be concealed by single-direction testing. Some cabling manufacturers require bi-directional testing as a condition of receiving a warranty on installed fiber cabling.

# WHITE PAPER

## Field Testing Installed Optical Fiber Cabling

A third problem may occur even if all the above problems are avoided. Fiber cabling that meets all TIA requirements for loss may not necessarily support an IEEE specified LAN application that an end-user desires to operate. For example, a TIA-568-C.1 compliant cabling installation with a Main Cross-connect, Intermediate Cross-connect, Horizontal cross-connect and a telecommunications outlet connector could have greater loss than the allowable channel loss for a higher performance IEEE specified LAN, even with relatively short link lengths (see the table on page 1).

Earlier revisions of TIA-568 allowed multimode backbone channels up to 2000m long. TIA-568-C.0 has removed these distance allowances that were often confusing to designers and users since they were inconsistent with actual supported distances. The TIA-568-C.0 Annex D includes an applications chart listing supported distances and cabling loss allowances (loss budgets) to assist in cabling design. For example, the supportable distances for 10GBASE-SR, the most commonly implemented form of 10 Gigabit Ethernet, are as follows:

FIBER TYPE	STANDARD 62.5/125 (OM-1) <sup>1</sup>	STANDARD 50/125 (OM-2) <sup>1</sup>	LASER OPTIMIZED 50/125 (OM-3) <sup>1</sup>	ENHANCED LASER OPTIMIZED 50/125 (OM-4) <sup>2</sup>
Bandwidth at 850nm (MHz-km)	200 <sup>3,4</sup>	500 <sup>4</sup>	2000 <sup>5</sup>	4700 <sup>2,5,6</sup>
<b>Maximum distance (meters/feet)</b>	33 (108) <sup>3</sup>	82 (269)	300 (98)	550 (1804) <sup>6</sup>

**Notes:**

- OM-1, OM-2 and OM-3 levels of performance were originally specified in the ISO-11801 international cabling standard; these designations were adopted in the TIA-568-C.3 revision, approved June 8, 2008.
- OM-4 was approved as an addition to TIA-568-C.3 in November 2009 specifying a bandwidth of 4700MHz-km.
- TIA-568-B.3 specified 160MHz-km bandwidth at 850nm for 62.5/125 multimode fiber, which supported a distance of 26m (82ft) for 10GBASE-SR; ISO-11801 specifies 200MHz-km bandwidth at 850nm for OM-1 62.5/125 fiber; the recently approved TIA-568-C.3 adopted the OM-1 specification of 200MHz-km, which increased the supportable distance to that shown above.
- These bandwidth specifications are based on Over-Filled Launch conditions (LED drivers).
- These bandwidth specifications are Effective Modal Bandwidth, based on Restricted Mode Launch conditions (vertical cavity surface emitting laser drivers).
- These are standard performance specifications for OM-4; other proprietary bandwidth and distance guarantees vary among manufacturers and can exceed OM-4.

When designing fiber cable plant, it is important to take into account the applications the cabling is intended to support immediately and applications that the system owner may wish to implement in the future.

# WHITE PAPER

## Field Testing Installed Optical Fiber Cabling

---

### PART 3: TROUBLESHOOTING

Despite following all these procedures, testing failures (unacceptably high loss) may occur. Many uncertainties are still present in fiber cabling, such as driver variance, fiber modal characteristics and tester performance. Standards help to reduce the uncertainties caused by these and other factors, though they cannot be controlled completely.

#### The most common causes of test failures are:

- contaminated connections
- failure to follow the connector manufacturer's recommended termination procedures
- damaged cable
- problems with the testers and jumpers themselves

The following practices may help resolve these issues:

### CLEANLINESS

Every fiber installation class dwells on cleanliness for good reason—as simple as cleaning is, poor cleanliness practices are the single greatest cause of problems in fiber testing and operation.

The most widely used method in the industry to clean a fiber connector is to wipe the connector ferrule with a lint-free paper or fabric pad moistened with alcohol. The alcohol helps to dissolve contamination that may be present on the ferrule. After cleaning with alcohol, the technician should take a clean dry wipe and polish the ferrule dry. If the connector is allowed to air dry, the contamination in the alcohol remaining on the ferrule is re-deposited on the ferrule as the alcohol evaporates.

To do proper cleaning, it is important to have the right materials. The alcohol should be "99% reagent grade isopropyl." Alcohol from a drugstore may look the same and smell the same and show

"isopropyl" on the label but it may be only 70% pure—plenty of room for impurities. The wipes used must be **lint-free** and made for this type of work. Pre-moistened wipes in foil packets are available and many technicians find them convenient.

Specialized solvents are available from tester manufacturers and from distributors that specialize in fiber supplies that can be more effective than alcohol. These are better than alcohol at dissolving some contaminants that are often present during fiber installation and termination, such as pulling lubricants and water blocking gels. These solvents are also non-hygroscopic (they do not draw moisture from the air) and are less likely than alcohol to leave a residue after evaporation.

Dry cleaning cassettes with an advancing tape inside are also available and can work well. Also available are cleaning cubes or cards that dispense small single-use pieces of cleaning wipes. Many in the industry recommend dry methods such as these as a first step in cleaning.

Canned air to blow adapters clean should be made for this purpose—keyboard cleaners from an office supply store can have many impurities. Buy from a source that specializes in fiber termination supplies and you should get "the right stuff." Canned air has only limited ability to remove many types of contamination. Special lint-free swabs dipped in solvent can remove contamination in an adapter that canned air may fail to dislodge.

It may take a few extra seconds, but if a technician cleans **every connector every time** immediately before the connector is inserted, it will save time in the long run. Problems will be prevented before they have to be found and solved.

After cleaning, the technician should put a dust cap on the connector immediately. This prevents damage to the ferrule and helps reduce contamination. There is dust in the air all the

# WHITE PAPER

## Field Testing Installed Optical Fiber Cabling

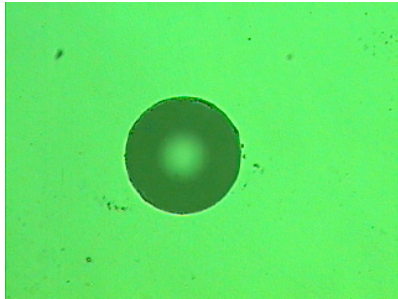

A clean ferrule

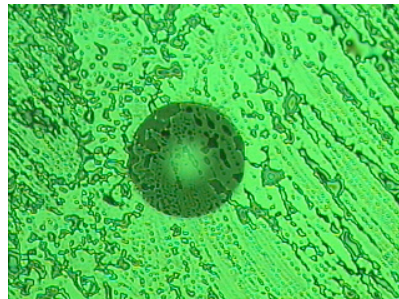

A ferrule after being touched by a "clean" finger

time—look closely at the beam in front of a bright projector. Some cleaning practices can even create an electrostatic charge that can attract dust out of the air. Even a capped connector should be cleaned before it is inserted—the plastic in some caps can deposit contamination on a ferrule. Do not touch the end-face of a ferrule. Even "clean" fingers will leave an oily coating on a ferrule.

Dust covers should be kept in all adapters in fiber enclosures until immediately before a connector is to be inserted. If a technician receives a failing test result for one link, the test cords should not be plugged into another port for comparison without cleaning first—contamination can easily be spread from one port to another.

It is especially important to keep the ports in

pre-terminated cassettes clean. Unlike traditional fiber cabinets that allow a technician to unplug a connector on the inside for cleaning, pre-terminated cassettes are generally factory sealed, making ports difficult to clean if contaminated. This is also true of the MPO ribbon connectors on the back of the cassettes—they are difficult to clean once contaminated.

Another practice that is becoming more common in the industry is inspecting connector ferrules before mating connectors. Microscopes are available that can display magnified images on a laptop screen or on small special-purpose video screens that make the process convenient for the technician. These microscopes can also view the end of a ferrule inside a factory sealed cassette to ensure it is clean before a connector is inserted.

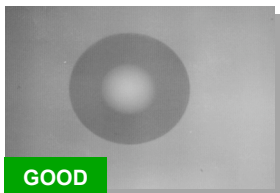

GOOD



EPOXY



CRACKED FIBER

### CONNECTORS

Connectors provide many possible causes of a testing failure, even after contamination is eliminated. Re-check connector end-faces with a microscope. A field-polished connector may have been poorly polished or damaged after termination.

If the connector looks like the center photo, additional polishing may remove the remaining adhesive. If the connector looks like the photo on the right, the fiber will probably have to be re-terminated.

# WHITE PAPER

## Field Testing Installed Optical Fiber Cabling

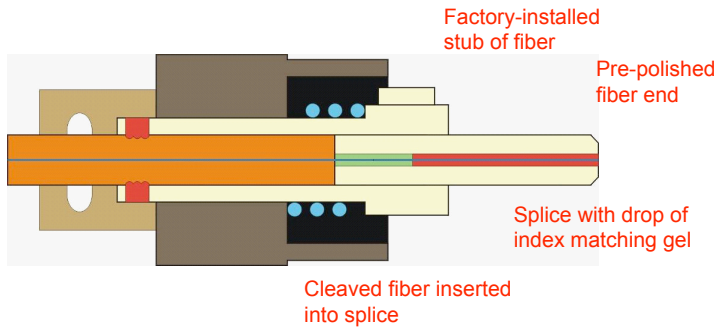

Pre-polished connectors, also called factory-polished or no-polish connectors, are popular with installers since they can be terminated in about half the time of a field-polish connector. As the name implies, a short piece of fiber is installed

in the connector and polished at the factory. The technician cleaves the fiber being terminated and inserts it into a small mechanical splice inside the connector.



These connectors can fail for two primary reasons: a bad cleave or an incompletely inserted fiber. If testing shows high loss and re-cleaning connectors does not correct the problem, an OTDR can locate the problem at one of the connectors or in the cable. If an OTDR is not available, the technician can continue troubleshooting through a process of elimination.

If a bad cleave is suspected, first check the cleaver itself. Cleave a few fibers in the cable being installed and check them under a microscope.

Microscopes for this purpose are available from some connectivity manufacturers and specialty fiber supply distributors. Use of this microscope after cleaving and before inserting the fiber can prevent assembling the connector with a bad cleave and wasting the connector.

As with other aspects of fiber termination, multimode connectors are more tolerant of marginal cleaves while singlemode connectors are more demanding.

# WHITE PAPER

## Field Testing Installed Optical Fiber Cabling

For a contractor installing sizable numbers of pre-polished connectors, an option to consider is buying a higher quality cleaver. The cleavers provided in most kits are in the few-hundred dollar range and are rated for only a few thousand cleaves. For four to five times that cost, a precision cleaver can offer certain benefits:

1. Increased productivity—the cleaves are reliably good and inspection by microscope or use of an inline loss measurement device is generally unnecessary
2. Increased yield—fewer connectors (virtually none) will be lost due to poor cleaves
3. Increased useful life—these cleavers are rated for roughly ten times as many cleaves as the cleavers supplied with most kits

The other common cause of high loss in a pre-polished connector is failure to insert the cleaved fiber far enough to make contact with the stub of fiber installed and polished at the factory. Index matching gel injected at the factory helps make the connection between the two pieces of glass, but they must meet inside the connector. The technician should feel a positive stop when inserting the fiber. Some manufacturers instruct

the technician to mark the fiber buffer to make sure it is fully inserted. Some rely on an inline loss detector with a Visual Fault Locator that indicates that the fiber is making a good connection inside the splice.

A common instance of this type of failure is terminating loose tube cable with pre-polished connectors. Loose tube cable contains fibers with 250 micron OD plastic coating. This is only a few times the thickness of a human hair, too fragile to be inserted directly into connectors. Before termination, the fibers must be inserted into 900 micron OD tubing and then cleaved and inserted. When inserting the cleaved fiber and the tubing into the connector, the fiber can be pushed back into the tubing, sometimes called pistoning, and fail to meet the fiber inside the connector.

The surest way to prevent this is to use field-polished adhesive connectors, though these require more labor to terminate. If pre-polished connectors are specified, care must be taken to leave some of the 250 micron coating on the fiber beyond the end of the 900 micron tubing, so that if the fiber pushes back into the tubing a little, the cleaved 250 micron coated fiber will still be fully inserted and make contact inside the connector.

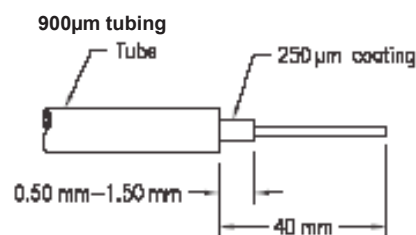
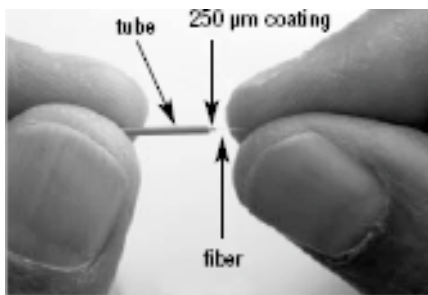

If all of the above fails to produce a satisfactory result, re-termination may be necessary. Without an OTDR to locate the cause of high loss, the problem could be the termination at either end (or in the cable, as discussed below—it is usually

easier to try re-terminating before replacing cable). You have a 50-50 chance. Re-terminate one end and retest. If that fails to correct the problem, re-terminate the other end and test again.

## WHITE PAPER

### Field Testing Installed Optical Fiber Cabling

---

Most of the practices in this article are also applicable to other methods of installing fiber, such as pre-terminated cassettes, mentioned above. Another method is splicing factory terminated pigtailed onto fiber cable. Mechanical splices have the same issues as pre-polished connectors, already discussed. Fusion splices, properly performed, are generally reliable and rarely cause testing problems.

The best way to prevent most of these problems is a practice that many technicians are reluctant to follow: **read the directions** and then follow them. It seems to be something that human nature resists. Engineers go to great effort to discover and document the procedure that will yield the best results. After cleanliness, the most common cause of warranty claims is failure to follow the manufacturer's directions.

For all termination problems, it is better (and cheaper) to discover, troubleshoot and correct a problem early. Many technicians have stories to tell that sound something like, "We did 2500 connectors on a project and when we went back to test them, they were all bad." These stories are distressing, and potentially expensive, for all involved—the customer (delay of the project), the installer (loss of labor cost), and the connector manufacturer (cost of replacement of materials).

Many things can go wrong in terminating fiber in the field, especially if a termination tool kit must be shared. Another technician who has used the kit, or simply the passage of time, can cause problems such as:

1. The polishing puck was dropped and chipped.
2. The polishing paper was used up and not replaced.
3. The polishing paper was used up and replaced with paper of the wrong grit.
4. The polishing paper was used up and replaced with paper of the correct grit but of poor

quality—uneven size of abrasive granules or uneven spacing of granules can produce poor polishing results.

5. The adhesive was used up and not replaced.
6. The adhesive has dried into a solid lump—anaerobic adhesives have a relatively short shelf life.
7. The adhesive may still appear useable but may be nearing the end of its life and not polish away properly, leaving a film that causes loss.
8. The cleaver may be worn out or damaged and produce bad cleaves.

The distress of discovering any of these problems only after completing a project is unnecessary. Before going to a jobsite, a technician should do a few connections with the same cable and connectors and tools that will be used on the project and **test** for acceptable results. At the jobsite, do a few more terminations and **test** them to make sure everything is working correctly. Then, terminate in small batches of perhaps 100 at a time and **test** a few. As confidence grows, so can the size of the batches.

If all the above practices do not resolve the cause of testing failures, contact the connector manufacturer before proceeding with the installation. They will probably request that you return samples of failing terminations including a short length of fiber attached. This will allow the manufacturer to analyze, diagnose and correct the problem before it becomes expensive.

#### CABLE

If all the connectors appear clean and properly terminated, the cause of high loss may be cable that has been over-stressed, crushed or bent too tightly during installation. If all the fibers in a single cable exhibit high loss, this is clearly indicated. A visual inspection may locate the

## WHITE PAPER

### Field Testing Installed Optical Fiber Cabling

---

problem. If not, this is a good application for an OTDR—it can tell you the approximate location of the damage.

If the high loss is in only one fiber, it may have been broken in handling after the outer jacket was removed. A Visual Fault Locator with a bright red laser can locate such a break in the fiber cabinet, since some of the light will escape at that point out of the side of the fiber and plastic coatings.

A tight bend causing loss in the cable may simply be straightened out if it is not too severe. If the cable is damaged, for example by being crushed in one place, that section may be removed and the ends spliced together. This is allowed by the standards as long as the measured end-to-end loss is acceptable.

If the damage is too extensive, the cable must be replaced. For example if the cable is pulled too hard by the jacket instead of by the strength member, microbends can be created along the entire length, giving the cable a “wavy” appearance. These microbends create high loss and the cable is not repairable.

#### TESTER ISSUES

In some cases, the cause of test failures is the test equipment itself. Field testers lead hard lives—exposure to temperature extremes, the dusty floors of vans, even occasional dropping. They must be maintained properly to give accurate results. Check with the tester manufacturer for the recommended schedule of factory recalibration. For copper twisted pair certification testers fitted with fiber modules, which are more complex than single-purpose OLTs, the recommendation is generally once a year. This important bit of maintenance is often neglected since the installer will be without the tester for a period of time and the recalibration will generally cost hundreds of dollars.

The performance of light sources in testers is governed by standards and ideally they would operate to precise limits and uniformly under all conditions. The real world, however, is seldom ideal and the following practices may help reduce uncertainty.

1. Before calibrating to set the reference, turn the tester on for 10-15 minutes to let the drivers stabilize.
2. Let the tester come to the room temperature at which it will be used before calibrating to set the reference, since driver output can change with temperature. If a tester has been sitting in a hot van in the summer or overnight in a van in the winter, this may take an hour or more.
3. Recalibrate and reset the reference after any event that can affect the amount of light being injected into the fiber, such as:
  - Disconnecting, reconnecting or changing the launch cord
  - Turning the tester off and back on
  - Moving the cord around in relation to the tester
  - Adding a mandrel
  - Recharging or replacing the batteries

Good batteries can be important for accurate results. As batteries get weaker, the voltage they provide drops and some testers will begin to give erratic results before the tester stops operating completely. If the tester uses disposable batteries, it is unlikely anyone will keep track of when the batteries were replaced, so at the end of each project throw the batteries away. Each job will then start with fresh batteries. If the batteries are rechargeable, but cannot make it through a single day without recharging, they should be replaced.

# WHITE PAPER

## Field Testing Installed Optical Fiber Cabling

### JUMPERS

The quality of jumpers or test reference cords should be checked by the TIA-568-C.0 process noted above, once a day before testing. If results become suspect, check the jumpers again—it takes only a few minutes. The standards require that connectors maintain their performance for 500 mating cycles. Jumpers with good quality ceramic ferrule connectors or hardened damage-resistant end-faces should have a useful life greater than this, but that life is not infinite. Replace the cords if:

1. They show any visible signs of wear
2. Test results become suspect and no other apparent cause is found
3. The jumpers fail the TIA-568-C.0 process
4. They have been used for a few thousand tests

One crucial practice that is easily overlooked is that the core size of the test jumpers must match the core size of the fiber being tested. Until a few years ago 62.5/125 micron fiber was most common so most existing test sets have that size jumpers. Now that 50/125 micron has become more common, jumpers with that core size must be used. Coupling light from a 62.5 micron core into a 50 micron core can cause a 3dB-5dB loss, depending on the modal distribution of the light in the core.

### ENCIRCLED FLUX

When testing multimode fiber, sources produce different modal power distributions if not controlled. Modal power distribution (MPD) is a way of explaining how many modes are supported by a multimode fiber. Multimode fiber can support hundreds of modes while a singlemode fiber typically supports one mode. This MPD is commonly referred to as a launch condition. Often, light sources from different manufacturers (and sometimes even within the same manufacturer) do not produce similar, repeatable launch

conditions, which can lead to variability in link loss measurements and, by extension, uncertainty about which test results are accurate.

Different types of light sources can produce different launch conditions. For example, a light emitting diode (LED) overfills a multimode fiber with many mode groups and results in excessive loss whereas a laser underfills a multimode fiber with few mode groups and could yield overly positive results—especially if the fiber plant includes misaligned connectors.

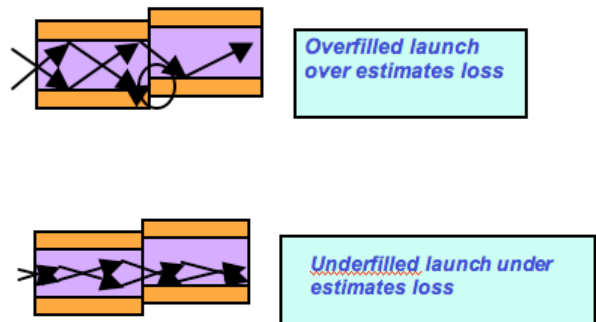

## WHITE PAPER

### Field Testing Installed Optical Fiber Cabling

---

As networking technology has evolved and loss budgets have decreased, link loss measurements are becoming more stringent. For example, at 2.6dB, the maximum loss for 10G Ethernet leaves very little room for error. Consequently, it is imperative that attenuation measurements are accurate and reproducible across different field test measurements.

Encircled Flux (EF) is a new standard for fiber testing methodology which tightens the loss variability to less than 10%. It is determined from the near field measurement of the light transmitted from the end of a reference grade test cord attached to the source. Compared to previous specified launch conditions such as MPD, which allowed significantly more variability, EF is a significant improvement. As new networking applications require more restrictive loss budgets, the use of Encircled Flux Launch Controller solutions that maximize testing accuracy and precision are becoming more important than ever.

#### APPLICATION FAILURE

After a cabling project is complete, an installer may get a trouble call from a customer who has an Ethernet link fail and suspects that the cabling is the cause. Before disturbing the cabling and potentially contaminating the connections, with the customer's permission, take a power reading with your meter at the transmit port on both ends of the failed link. If the customer does not have documentation to show the nominal power output, measure the power from a known good transmit port and compare that to the failed port. The fault is very possibly with the electronics and not the cable.

#### CONCLUSION

Though perfection in testing in the real world is elusive, using all of the best practices available will avoid the pitfalls and misconceptions that often lead to inaccurate field test results. This will give the best assurance of delivering to the end-user a cabling system with a long useful life that will support the high-performance LANs on which we all depend.

For more information, please contact us at 877-599-5393 or visit our web site at [www.legrand.us/ortronics](http://www.legrand.us/ortronics)

#### WANT MORE INFORMATION?

Want to learn more about how to certify, test, and troubleshoot your optical fiber network? With condensed and full-length versions available, Fluke Networks has created a concise, yet comprehensive guide to help you ensure proper assessment of cable installation quality and efficient troubleshooting to minimize the time spent identifying and correcting the root cause(s) of problems.

Condensed version: [www.flukenetworks.com/fiberquickguide](http://www.flukenetworks.com/fiberquickguide)  
Extended version: [www.flukenetworks.com/fiberhandbook](http://www.flukenetworks.com/fiberhandbook)