

40/100 Gb/s Ethernet Over Multi-mode Optical Fiber

Planning for Infrastructure
Readiness

40/100 Gb/s over MMF

- Evolution of Ethernet
 - 40/100 Gb/s Ethernet Adoption Timeline
 - Server port growth
 - IEEE 802.3ba Objectives
 - OM3
 - Link and Cable Characteristics
- Achieving 40/100 Gb Ethernet
- Issues
- Cabling Recommendations
- What's the Bill
- Summary

Ethernet Timeline

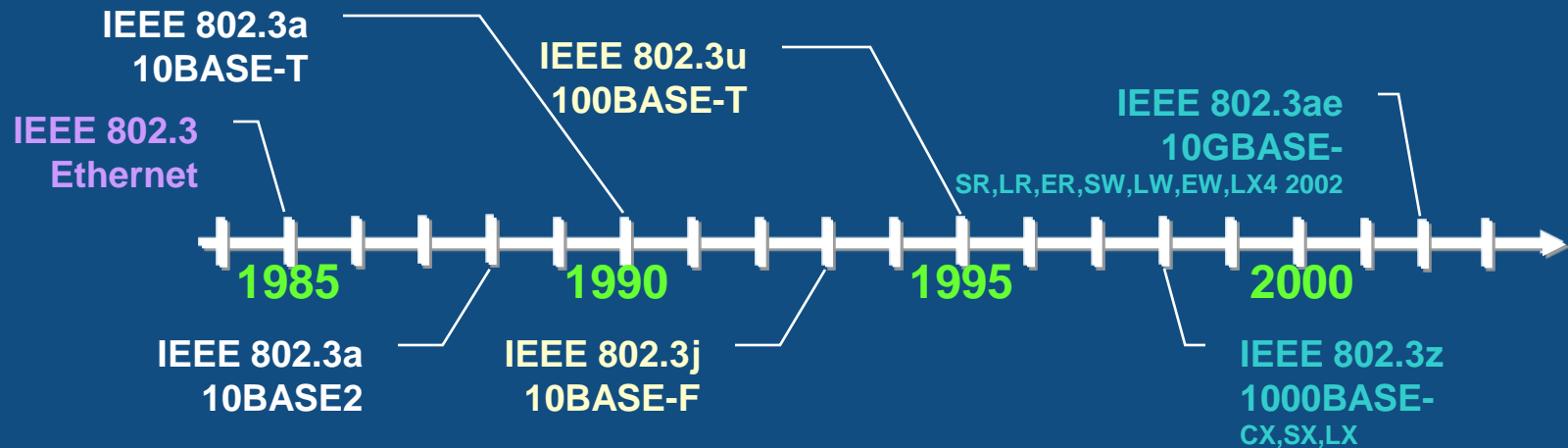

	Time to Reach (years)	
	Million Port Sale (after Ratification)	60% Market Penetration
10 Mb E	1	
100 Mb E	1	5
1000 Mb E	2	9
10 Gb E	6	10+

Flatman, LAN Technologies, 2007

40/100 Gb Ethernet

x86 Servers by Ethernet Connection Speed

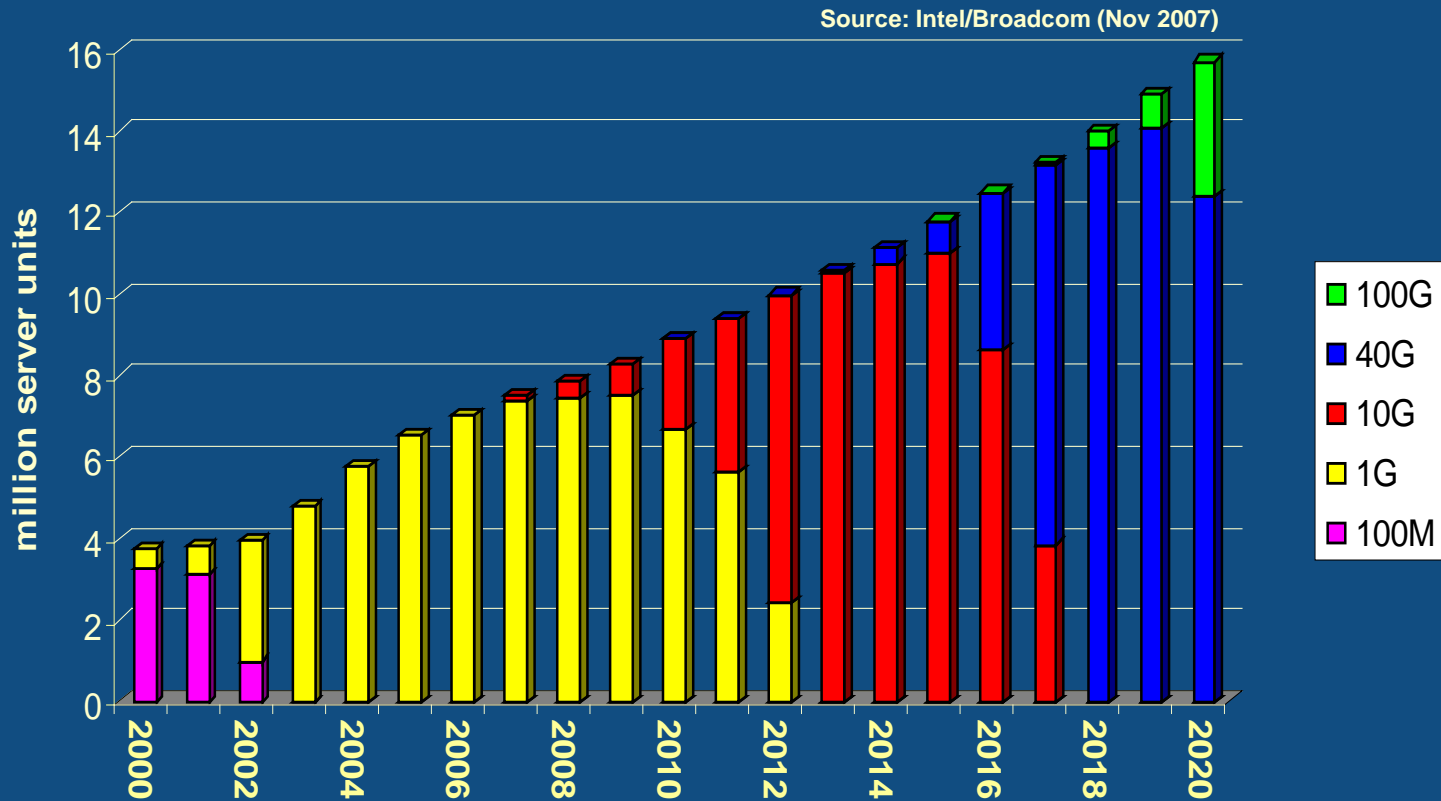

IEEE 802.3ba Objectives

- Provide Physical Layer specifications which support 40 Gb/s operation over:
 - At least 100m on OM3 MMF
 - At least 10m over a copper cable assembly
 - At least 1m over a backplane
- Support a MAC data rate of 100 Gb/s
- Provide Physical Layer specifications which support 100 Gb/s operation over:
 - At least 40km on SMF
 - At least 10km on SMF
 - At least 100m on OM3 MMF
 - At least 10m over a copper cable assembly

. . . at least 100m on OM3 MMF

- OM3* multi-mode fiber is:
 - 50/125 μm
 - 2000 MHz•km EMB**, minimum, at 850 nm
- ANSI/TIA-598-C Optical Fiber Cable Color Code
 - Indoor cable with AQUA jacket

* Type A1a.2 as specified in IEC 60793-2-10

** Effective Modal Bandwidth

Link and Cable Characteristics*

- Supported fiber types
 - 50/125 μm , OM3
- Effective Modal Bandwidth (EMB)
 - 2000 MHz•km** minimum
- Power Budget
 - Greater than 8.3 dB***
- Channel Insertion Loss
 - 1.9 dB

*As of December 2008

**Launch Condition Dependent

***For Further Study

Connector Loss Under Study



40/100 GbE over MMF

- Evolution of Ethernet
- Achieving 40/100 Gb/s Ethernet
 - Enabling Technology
 - Parallel Optics, 40 Gb/s
 - Polarity Today
 - Parallel Optics, 100 Gb/s
 - Polarity
 - Recap
- Issues
- Cabling Recommendations
- What's the Bill
- Summary

Enabling Technology

- Multilane Distribution (MLD) – Parallel Links
 - 40 Gb/s equals 4x fibers each for Tx and Rx
 - Each carrying a 10 Gb/s signal
 - 100 Gb/s equals 10x fibers each for Tx and Rx
 - Each carrying a 10 Gb/s signal

Today, two fibers can support full duplex 10 Gb/s

40 Gb/s will require 4x the fiber count

Parallel Optics, 40 Gb/s

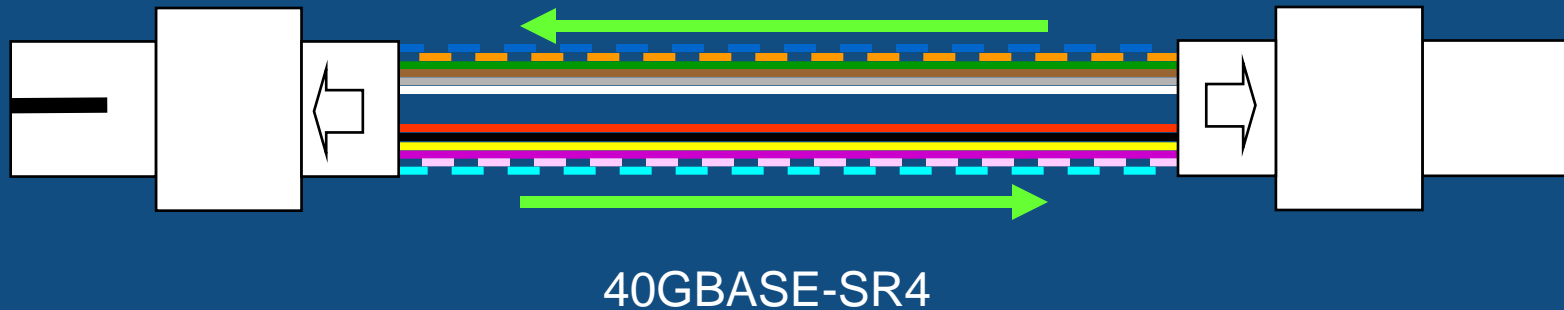

- MTP™*/MPO (Multi-fiber Push On) Connectors
- 8 or 12 Fiber Loose Tube or Ribbon cable
- Likely a pre-terminated assembly solution

*MTP is a registered trademark of USCONEC

Parallel Optics – Polarity Today

Type-A MPO-to-MPO array cable

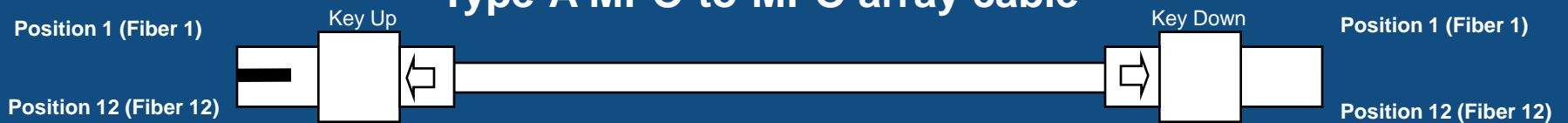

Type-B MPO-to-MPO array cable

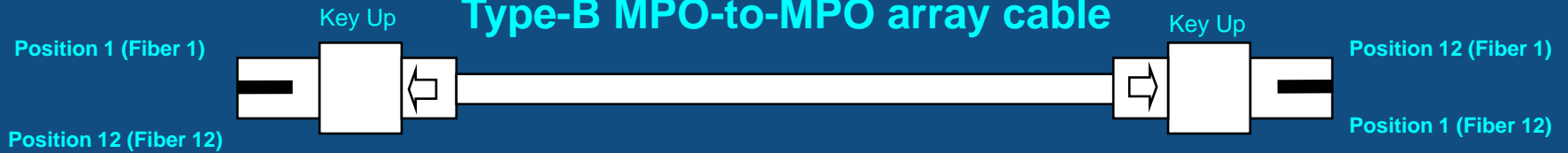

Type-C MPO-to-MPO array cable

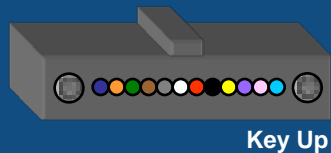
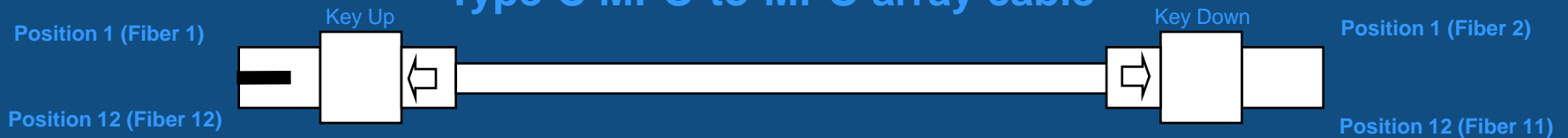

TIA-568-C.3

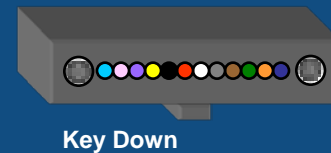

Parallel Optics, 100 Gb/s

- 100 Gb/s will use 10 fibers per Tx to Rx link
- Two 12F MTP/MPO connectors, or
- 24-Fiber MTP/MPO connections can significantly reduce pre-terminated connection costs and increase connection densities
- No standards on 24F polarity at this time



Parallel Optics – 24F Polarity

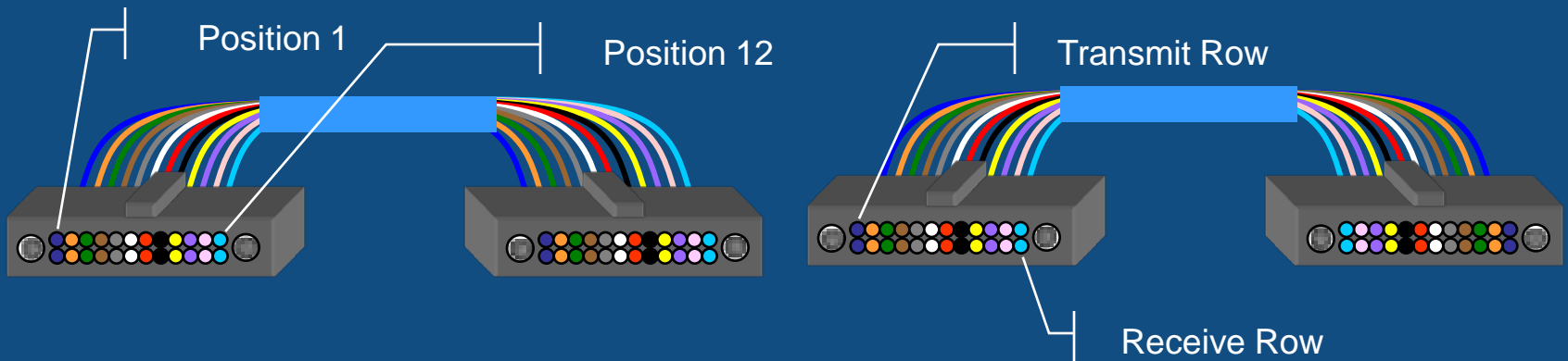

- 10 channel links for 100 Gb/s
 - Require 2x quantity of 12F MTP/MPO's, or
 - 24F MTP/MPO's
 - 24F Polarity resolution undefined

Recap

- 40/100 Gb/s will use
 - Multiple fibers per Tx/Rx link
 - Minimum of OM3 specified, 2000 MHz•km @ 850 nm
 - MTP/MPO connectors
 - Loose tube or ribbon cabling compatible with MTP/MPO
 - Preterm likely the norm
 - Polarity puzzle

40/100 GbE over MMF

- Evolution of Ethernet
- Achieving 40/100 Gb Ethernet
- Issues
 - Arrival Time
 - Optical Skew
 - Skew Measurement
 - Skew Results
- Cabling Recommendations
- What's the Bill
- Summary

Arrival Time



- Multi-lane signals launch simultaneously
- Fiber length and modal paths vary
- Signal components arrive out of sync

This difference in arrival time is optical skew

Is Optical Skew a Problem?

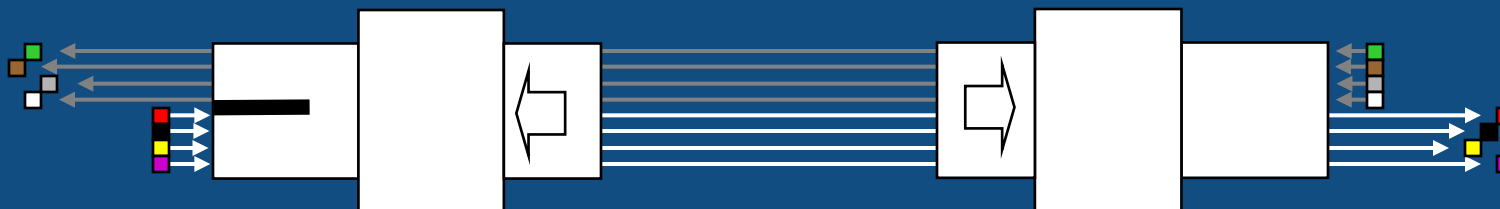

- Transmission media (optical fiber) major contributor to skew
 - Proposed allowance* for skew due to transmission media
 - 100 ns
 - Expected maximum contribution from optical media
 - 13.6 ns
- Is a particular cable construction better in minimizing transmission optical skew?

* 100GE/40GE skew budget, IEEE 802.3ba TF, Dallas November 2008, Gustlin/Anslow/Giannakopoulos

Optical Skew Measurement

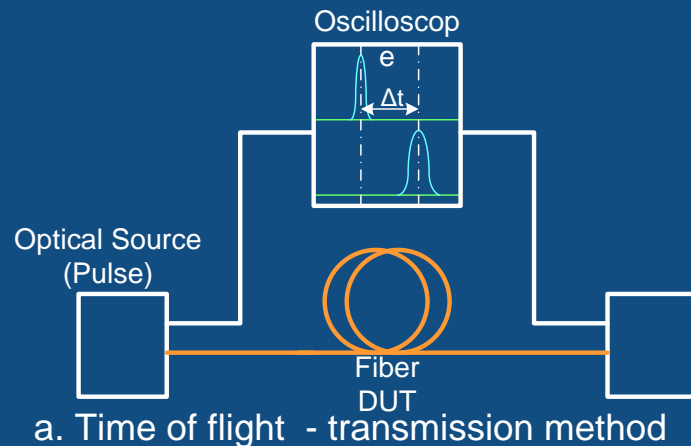

- Method A

- Transmit a pulse down the fiber
- Measure arrival time
- Repeat for all fibers
- Calculate maximum difference

- Method B

- Transmit a pulse down the fiber
- Measure arrival time of reflections
- Repeat for all fibers
- Calculate maximum difference

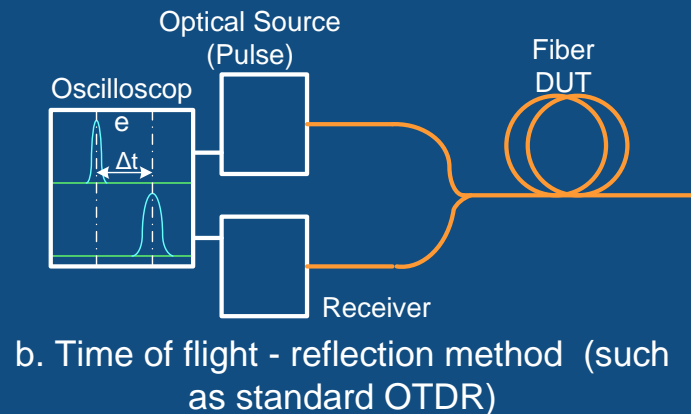

Optical Skew Measurement

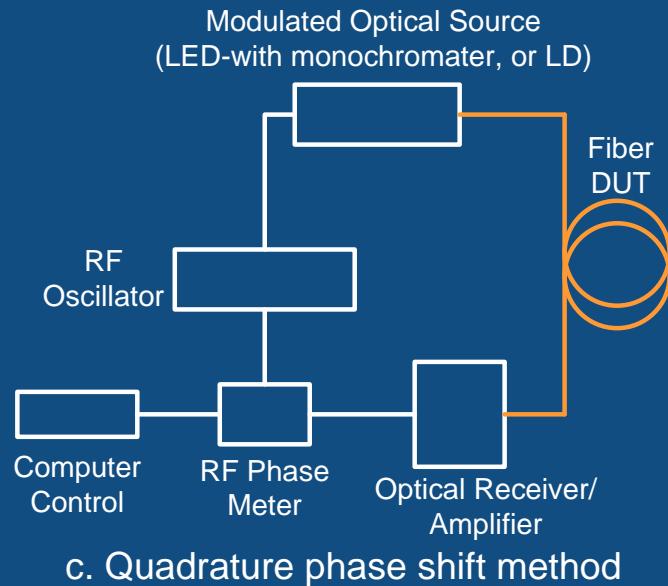

- Method C

- Launch RF modulated optical signal down each fiber using single mode optics
- Measure the phase difference of received RF signal with the reference, using a precise phase meter: propagation delay
- Calculate maximum delay difference

Skew Measurement Results

- Quadrature Phase Shift Testing
 - 100 meter test length
 - Loose Tube tested maximum
 - 0.8 ns
 - Ribbon tested maximum
 - 0.3 ns
- Proposed Skew Allowance for 40GBASE-SR4 and 100GBASE-SR10
 - 100 meter length
 - 100 ns (over 100 times measured maximums)

For Optical Skew neither loose tube cabling or ribbon cabling a problem

40/100 GbE over MMF

- Evolution of Ethernet
- Achieving 40/100 Gb Ethernet
- Issues
- Cabling Recommendations
 - Size and Bend
 - Fiber Count
- What's the Bill
- Summary

Size and Bend



Reduced O.D. 48F Loose Tube Cable (0.231")



48F Loose Tube Cable (0.370")

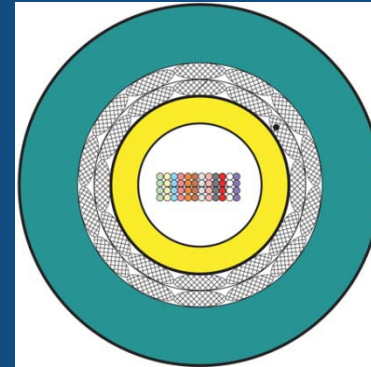

48F Stacked Ribbon Cable (0.520")

- Optical Skew
 - Loose Tube and Ribbon cabling
 - Optical skew adequately handled by electronics
- Preferential Bending Limits Flexibility
 - Loose Tube Cabling
 - No preferential bend
 - Ribbon Cabling
 - Has preferential bend

Fiber Count Requirements (1)

- Today, a 12F, OM3, MPO-MPO backbone link
 - Provides up to six full duplex 10Gb/s Tx/Rx pairs
- 40GBASE-SR4
 - Requires a minimum of eight OM3 fibers for a Tx/Rx link
 - 4 fibers Tx
 - 4 fibers Rx
 - Should be able use installed legacy 10GBASE-SR links
 - 100m length
- 100GBASE-SR10
 - Requires a minimum of 20 OM3 fibers for a Tx/Rx link
 - 10 fibers Tx
 - 10 fibers Rx

Fiber Count Requirements (2)

- Legacy 10 GbE systems may not be directly mappable to 40/100 Gb/s
 - A legacy 144F MPO-MPO backbone
 - Will support 12x 40GBASE-SR4 duplex links
 - May support 6x 100GBASE-SR10 duplex links
- For 40GBASE-SR4
 - Anticipate 8/1 ratio on fiber count to link
 - A 144F cable will support 18x 40Gb/s Tx/Rx links
- For 100GBASE-SR10
 - Anticipate 20/1 ratio on fiber count to link
 - A 144F cable will support 7x 100Gb/s Tx/Rx links

40/100 GbE over MMF

- Evolution of Ethernet
- Achieving 40/100 Gb Ethernet
- Issues
- Cabling Recommendations
- What's the Bill
 - Link Cost on OM3
 - About single mode
 - OM3 and OS2
 - About OM4
- Summary

Link Cost on OM3

- Traditional rule of thumb, 3x cost increase for 10x performance increase
 - Not likely to hold for 40/100 Gb/s
 - Estimates very preliminary, around 4x for 40GBASE-SR4
- 10GBASE-SR, XFP
 - About \$1300, 2008
 - 4x equals \$5200. 2x ports equals \$10,400
- 12F, OM3, Loose Tube Plenum, 100m length
 - About \$500

Total Link Cost \$10,900, estimated

About Single Mode

- Not Parallel Optics
- Initial release using CWDM
 - 40GBASE-LR4 uses 4x 10 Gb/s wavelengths
 - 100GBASE-LR4 will likely use 4x 25 Gb/s wavelengths
- Estimate of 6x* cost of 10GBASE-LR
 - Expected cost reductions with technology/optimization improvements
- 10GBASE-LR, XFP \$1600
 - 6x = \$9600, Times 2 ports = \$19,200
- 12F, OS2, Loose Tube Plenum, 100 m length
 - \$200

* 40GbE Market: Timing and Opportunity, Alessandro Barbieri, September 2008 IEEE Seoul

OM3 and OS2

- Estimated link cost for 40GBASE-SR4
 - \$10,900
- Estimated link cost for 40GBASE-LR4
 - \$19,400
- Cost difference OM3 → OS2
 - + \$8,500

About OM4

- Current 10GBASE-SR uses VCSEL's
 - RMS Spectral width about 0.25 nm
 - That is a tight light source
 - When you combine low modal dispersion of OM4/OM3 fiber with low chromatic dispersion of this laser – you go farther
- Initial 40/100 Gb/s specification calls for
 - RMS Spectral width of 0.65 nm
- Why?
 - Reduce costs of transmitters and receivers
 - Early adopters of 40/100 Gb/s will be data centers/SAN's

40/100 GbE over MMF

- Evolution of Ethernet
- Achieving 40/100 Gb Ethernet
- Issues
- Cabling Recommendations
- What's the Bill
- Summary
 - 40/100 Gb/s Redux

40/100 Gb/s Redux

- OM3 multi-mode fiber specified
 - 2000 MHz•km EMB at 850 nm
- At least 100 meter runs supported
- Parallel optics used
 - MTP/MPO
- Optical skew exists but is compensated for by active components
 - Observed skew 100 times less than specified
- Optical cabling recommendations
 - Loose tube, no bending preference
- Cost

Alfred Flores
Berk-Tek, a Nexans Company

alfred.flores@nexans.com

